



SIC278

FDX-A/-B, FSK FECAVA, ISO11784/85, 1408-bit High Performance R/W RFID Transponder IC
REV 1.0

Features Summary

Highlight Features

- High performance read range by SIC's boost-up technique
- Frequency range 100 - 150kHz
- Integrated resonant capacitor of 210pF
- Air-tuneable resonant capacitor for maximum read range
- Extremely low power consumption in read mode
- Two levels of password authorization (Read and Read/Write)

Supported Protocol

- FDX-A, FSK FECAVA
- FDX-B, ISO 11784/85 Animal ID
- 64-bit ID format, data rate 2 kbit/s
- Downlink, 100% ASK, 5.2 kbps pulse interval coding
- Uplink, Deep ASK modulation with Anti-collision Manchester, DBP, and FSK (FECAVA) coding
- Selectable uplink data rate 2, 4, 8 kbps (RF/64, RF/32, RF/16 respectively)
- Anti-collision (up to 30 tags/s)
- CRC for Data integrity check
- Tag-talk-first mode (TTF) with configurable max block up to 256 bits

Memory

- Factory programmed 7-byte UID
- 1408 bits (44 x 32) EEPROM
- 1184 bits (37 x 32) in user memory area
- 100,000 erase/write cycles
- 10 years of non-volatile data retention
- Secure memory lock functionality
- 32-bit Unique Identification Number (UID)
- 64-bit Traceability data

Package

- WDFN 1.5x1.8 mm

Application

- Livestock Management/ Breeding control
- Animal Identification
- Automation in industry
- Access control

Revision History

Revision	Date	Change/Update Comment
1.0	6 Mar 2026	Official release

Ordering information

Part No.	Description	Package	Standard Packing
P78BWD A1P20UT7810E3	SIC278-10, LF FDX IC with RW memory 1 kbits and Animal ID DFN 0.75 mm, TnR, IC	WDFN (1.5x1.8 mm)	3,000 pcs/Reel

The information herein is for product information purpose. While the contents in this publication have been carefully checked; no responsibility, however, is assumed for inaccuracies. Silicon Craft Technology PLC. reserves the right to make changes to the products contained in this publication in order to improve design, performance or reliability.

Contents

0. Notation.....	8
0.1 Styles and Fonts for key words.....	8
0.2 Abbreviation	9
1. Functional Overview.....	10
1.1 Block Diagram.....	10
1.1.1 Analog Front End (AFE).....	10
1.1.2 Digital Controller and Memory.....	11
2. Specification.....	12
2.1 Absolute Maximum Rating.....	12
2.2 Electrical Characteristics	12
3. State of operation	13
3.1 General Description of States.....	13
3.1.1 Power OFF State	13
3.1.2 Ready State	13
3.1.3 INIT State	13
3.1.4 Selected State.....	14
3.1.5 SILENT State	14
3.1.6 Tag-Talk-First (TTF) State	14
4. Memory organization.....	15
4.1 Package and Dimension Unique Identifier (UID).....	15
4.1.1 Product Identifier (PID)	15
4.2 SIC278 in Standard Mode.....	16
4.3 SIC278 in Password Mode	16
5. SIC278 Configuration.....	17
5.1 Configuration block	17
5.2 Factory Default Memory	19
6. Communication.....	20
6.1 Downlink Mode	20
6.1.1 Coding.....	20
6.2 Uplink Mode	21
6.2.1 Coding Technique of SIC278 Transponder IC	21
6.2.2 Data Rate	22
6.3 Wait Timing (Idle time before next communication)	23

6.3.1	Read/Write Equipment waiting time before sending the first command	23
6.3.2	Read/Write Equipment waiting time before sending a subsequent command	23
6.3.3	Reset Time.....	24
6.3.4	SIC278 Waiting Time before transmitting a response after receiving an EOF.....	24
6.3.5	SIC278 Transponder Programming Time	25
6.3.6	SIC278 Waiting Time before transmitting data in TTF Mode	26
6.3.7	SIC278 Transponder Mode Switching Time.....	26
7.	Commands	27
7.1	GET_UID xx	27
7.2	Anti-C SEQUENCE	28
7.3	WRITE CT	28
7.4	READ CT	29
7.5	SELECT (UID)	29
7.6	UNLOCK PASSWORD	30
7.7	SELECT_SILENT (UID)	31
7.8	READ BLOCK.....	31
7.9	READ PAGE.....	32
7.10	WRITE BLOCK	32
7.11	WRITE PAGE	33
7.12	SILENT	34
8.	Public Mode.....	35
8.1	ISO11784/85 Animal ID Using 128 Bit TTF Mode (FDX-B)	35
8.2	FECAVA Animal ID	36
8.3	64-bit ID Format.....	37
9.	CRC Calculation / Integrity Check.....	38
9.1	Data Transmission: RWE to SIC278 transponder	38
9.2	Data Transmission: SIC278 transponder to RWE	38
9.2.1	Standard Response Protocol Mode	38
9.2.2	Advanced/ Fast Advanced Response Protocol Mode	38
9.3	CRC Checksum Source Code	39
10.	Package Information	40
10.1	WDFN 1.5x1.8 mm	40
11.	Disclaimer.....	41

List of Figures

Figure 1-1: SIC278 Functional block diagram.....	10
Figure 3-1: SIC278 State diagram	13
Figure 4-1: SIC278 Memory Organization.....	15
Figure 4-2: Unique Identifier (UID).....	15
Figure 4-3: Memory Map for SIC278 in Standard Mode	16
Figure 4-4: Memory Map for SIC278 in Password Mode	16
Figure 5-1: Configuration block.....	17
Figure 5-2: Factory Default Memory.....	19
Figure 6-1: Data transmission from RWE to transponder	20
Figure 6-2: Example of Data Transmission for Uplink Mode (Tag to Reader)	21
Figure 6-3: Coding Techniques of SIC278 Transponder	21
Figure 6-4: Read/Write Equipment Waiting Time before sending the first command	23
Figure 6-5: Read/Write Equipment Waiting Time before transmitting a subsequent command	23
Figure 6-6: SIC278 Waiting Time before transmitting a response after receiving an EOF	24
Figure 6-7: SIC278 Transponder Programming Time	25
Figure 6-8: SIC278 Waiting Time before transmitting data in TTF Mode.....	26
Figure 6-9: SIC278 Transponder Mode Switching Time	26
Figure 7-1: GET_UID Bit Stream	27
Figure 7-2: Anti-C SEQUENCE.....	28
Figure 7-3: WRITE CT	28
Figure 7-4: READ CT	29
Figure 7-5: SELECT (UID).....	29
Figure 7-6: UNLOCK PASSWORD	30
Figure 7-7: SELECT_SILENT (UID).....	31
Figure 7-8: READ BLOCK	31
Figure 7-9: READ PAGE	32
Figure 7-10: WRITE BLOCK	32
Figure 7-11: WRITE PAGE	33
Figure 7-12: SILENT	34
Figure 8-1: Configuration for 128-bit TTF with differential bi-phase coding	35
Figure 8-2: Transponder Data Transmission – 128 bits TTF Mode.....	35
Figure 8-3: 128-bit FDX-B data format and RF signal structure of differential bi-phase coding, RF/32 data rate	35
Figure 8-4: Configuration for 96-bit TTF with FSK coding.....	36
Figure 8-5: Transponder Data Transmission – 96 bits TTF Mode	36
Figure 8-6: 48-bit FDX-A data format and RF signal structure of FSK coding, RF/100 data rate	36
Figure 8-7: Configuration for 64-bit ID TTF with Manchester coding	37
Figure 8-8: Transponder Data Transmission – 64 bits TTF Mode	37
Figure 8-9: 64-bit ID format and RF signal structure of Manchester coding, RF/64 data rate.....	37
Figure 10-1: WDFN 1.5x1.8 mm Package Drawing	40

List of Tables

Table 0-1: Style and Fonts key word	8
Table 0-2: Abbreviation	9
Table 2-1: Absolute Maximum Rating	12
Table 2-2: Electrical Characteristics	12
Table 2-3: EEPROM Characteristic.....	12
Table 5-1: SIC278 Max-Block.....	17
Table 5-2: SIC278 Coding Bit (MC/DBP).....	17
Table 5-3: SIC278 Password Bit (PWD_W, PWD_R Bit)	18
Table 5-4: SIC278 Data Rate Bits (DR(0) and DR(1)).....	18
Table 5-5: SIC278 Lock Configuration	18
Table 5-6: SIC278 Memory Lock Bits Description	18
Table 6-1: Illustrates the data transmission from the RWE to SIC278 tag.....	20
Table 6-2: Data rate Mode Description	22
Table 6-3: t_{wfc} Waiting Time Range	23
Table 6-4: t_{wsc} Waiting Time Range.....	24
Table 6-5: t_{reset} Minimum time	24
Table 6-6: t_{wresp} Waiting Time Range	25
Table 6-7: t_{prog} or t_{CT_prog} Waiting Time Range.....	25
Table 6-8: t_{TTF} Waiting Time Range.....	26
Table 6-9: t_{switch} Waiting Time Range	26
Table 7-1: Coding.....	27
Table 7-2: GET_UID Response Protocol Mode Description.....	27
Table 7-3: Anti-C SEQUENCE Response Protocol Mode Description.....	28
Table 7-4: SELECT (UID) Response Protocol Mode Description	29
Table 7-5: UNILOCK PASSWORD Response Protocol Mode Description	30
Table 7-6: SELECT_SILENT (UID) Response Protocol Mode Description.....	31
Table 7-7: READ BLOCK and READ PAGE Response Protocol Mode Description.....	32
Table 7-8: WRITE BLOCK Response Protocol Mode Description	33
Table 7-9: WRITE PAGE Response Protocol Mode Description.....	33
Table 7-10: SILENT Response Protocol Mode Description	34

0. Notation

0.1 Styles and Fonts for key words

This part defines styles and fonts used for the key words throughout this document. The key words are names of signal, register, pin, state of operation and command. The styles, fonts, and their indications are shown in Table 0-1.

Table 0-1: Style and Fonts key word

Symbol	Indication
<i>Signal</i>	Signal name
Register	Register name or Bit name
pin RX	Pin name
<i>“State of Operation”</i>	State of operation
Command	Command name for RF interface
“Flag”	Flag name in response state

- To refer to a register address and a value in a register, a hexadecimal number proceeding with letter “0x” is used, for example 0x0A.
- To refer to a bit located in a register address, a symbol “.” following by a number reflecting the bit location starting from 0 to 7 is used. For example, 0x0A.0 refers to bit 0, least significant bit, in the register 0x0A.
- To refer to a set of consecutive bits located in a register address, a format “[msb:lsb]” is used after a register value. For example, a value of 0x0A.[3:0] refers to bit 3, 2, 1, and 0 in the register 0x0A.
- To refer to a binary value in some registers, the letter “b” is placed at the end of the binary number, for example “1010b”.
- To refer to logic level, the number in single quote ‘1’ and ‘0’ are used to refer to binary logic level.

0.2 Abbreviation

Table 0-2: Abbreviation

Abbreviation	Term
ACK	Acknowledge
AFE	Analog-Front-End
Anti-C	Anti-collision Code
BADR	Block address (1 block = 32-bit data)
BiPh	Bi-phase
CON	Configuration
CRC	Cyclic Redundancy Check
DIT	Die In Tray
EEPROM	Electrically Erasable Programmable Read-Only Memory
EOF	End of Frame
fc	Carrier Frequency
LSB	Least Significant Bit
LSByte	Least Significant Byte
MSB	Most Significant Bit
MSByte	Most Significant Byte
OTP	One-time program
PID	Product Identifier
POR	Power-on-reset
PWD	Pre-defined password
RES	Reserved
RFID	Radio frequency identification
RO	Read Only
R/W	Read/Write
RWE	Read/Write Equipment
SIC	Silicon Craft Technology
SOF	Start of Frame

1. Functional Overview

SIC278 is a read/write low-frequency FDX RFID microchip intentionally designed to maximize read range. The on-chip 1184-bit EEPROM allows additional information to be stored for custom user applications or an on-site database. The chip contains a 32-bit Unique Identification number (UID) for Anti-collision and 64-bit traceability data for optional identification. The chip has a 2-level password for read authorization and read/write authorization.

The chip can be configured to serve the most popular standard in low-frequency RFID, such as FECAVA, FDX-A, FDX-B, and 64-bit ID format, or a proprietary system. Communication mode can be set either in tag-talk-first (TTF) mode to use in a traditional system or reader-talk-first in applications requiring anti-collision.

In terms of performance, the SIC boosting-up technique, deep modulation (Coil damping), and extremely low power consumption design are employed to obtain increasing performance in read range. SIC278 incorporates a tunable resonant capacitor to accommodate variation of inductance in the production process to bring the resonant frequency of the transponder to the target. Adjusting the tuning capacitor read range on production yields.

1.1 Block Diagram

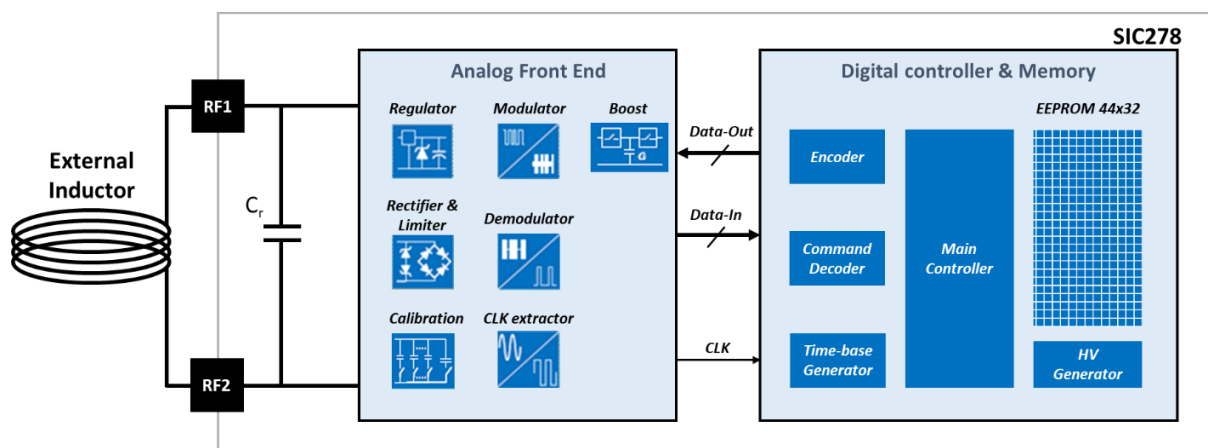

Figure 1-1: SIC278 Functional block diagram

1.1.1 Analog Front End (AFE)

The SIC278's Analog Front End receives power and data from the coupling of an RF signal through an external LC resonant circuit known as the inlay/inlet's antenna circuit. The AFE creates the IC's power supply and handles bidirectional data communication with the reader/scanner unit.

The SIC278 consists of the following blocks:

- Full-wave Bridge Rectifier

The Bridge Rectifier with an internal decoupling converts the induced AC signals to a proper DC level for the entire chip.

- Current-Bias Circuitry, POR, and Series Regulator

The Current-Bias Circuitry works with the Series Regulator to generate a stabilized supply for the digital and memory. The POR operates by detecting the supply level crossing a valid operating threshold during system power-up.

- The RF Limiter and Load Modulator

The RF limiter is used to protect the chip from damage caused by the tag being present in an extremely strong RF field. The signal during load modulation threshold of the RF limiter is

also controlled by the modulation signal during load modulation or the “uplink”, thus, amplitude modulating the reader’s coil signal.

- Demodulator

The envelope of the induced RF signal is encoded with data by the reader during the “Downlink”. SIC278 detects changes in the envelope of the signal and converts them into a digital signal by the demodulator.

- Clock Extractor

The clock extractor generates a system clock reference corresponding to the RF field frequency. The clock is used for timing the state machines inside the chip.

1.1.2 Digital Controller and Memory

- Command Decoder

The demodulated signal from the demodulator is further decoded into logical data by the command decoder. Decoded logical data is checked for a valid format for Write mode or the “Downlink”.

- Controller State Sequencer

The sequencer performs the following functions:

- Load chip’s configuration data from memory at initialization
- Control read/write data from/to the memory
- Control and handle password-accessing modes
- Interpret instructions and data from the command decoder and execute a valid one
- Perform anti-collision sequence

- Encoder

The encoder encodes the baseband’s bit-stream data into an appropriate format for RF transmission, such as Differential Bi-phase and Manchester at multiple data transmission rates, RF/32, RF/50, and RF/64.

- Memory

The memory is non-volatile Electrically Erasable Programmable Read-Only Memory (EEPROM) and has a capacity of 1,408 bits organized in 44 blocks of 32 bits (4 bytes). The high-voltage generator is included to provide a voltage to erase or program data into the memory.

2. Specification

2.1 Absolute Maximum Rating

Conditions above the listed maximum ratings may cause permanent damage to the device. Exposure to the absolute maximum rating conditions for an extended period may affect the device's reliability. Only one absolute maximum rating can be applied at a time.

Table 2-1: Absolute Maximum Rating

Parameter	Description	Rating
T _{op}	Operating temperature	-40 °C to +85 °C
T _{storage}	Storage temperature	-40 °C to +125 °C
V _{ESD}	Electrostatic Discharge ⁽¹⁾	2000V

(1) HBM model

2.2 Electrical Characteristics

Table 2-2: Electrical Characteristics

Parameter	Description	Min	Typ	Max	Unit	Conditions
f _{op}	RF operating frequency	100	134.2	150	kHz	
V _{rd}	Input Voltage for Read	3			V _p	
V _{wr}	Input Voltage for Write	7			V _p	
C _{res}	Resonance capacitance (CT=0)	193	200	207	pF	V _{RF1-RF2} = 2.5 V _{rms}
CT	Tunable capacitance	0		22	pF	V _{RF1-RF2} = 2.5 V _{rms}
CT _{step}	Tunable capacitance step		0.7		pF	V _{RF1-RF2} = 2.5 V _{rms}
P _{rd}	Operation power for Read	15			uW	
P _{wr}	Operation power for Write	80			uW	

Table 2-3: EEPROM Characteristic

Parameter	Description	Min	Typ	Max	Unit	Conditions
MEM	Memory		1408		bits	
T _{ret}	EEPROM Data Retention	10			Years	T _{amb} = +55°C
N _{cy}	EEPROM write cycles	100k			Cycles	T _{amb} = +55°C

3.1.4 Selected State

After a valid **SELECT (UID)** command is sent, the transponder will enter this state. There is only one SIC278 transponder in the field of the RWE antenna that can be in the **"Selected"** state at the same time.

If the **PWD_R** and/or **PWD_W** bit is not set, read/write commands can be used.

If the **PWD_R** and/or **PWD_W** bit is set, a 32-bit password must be sent to unlock it before using read/write command.

3.1.5 SILENT State

After a valid **SELECT_SILENT** command is sent in the **"INIT"** state or a **SILENT** command is sent in the **"Selected"** state, the transponder will enter this state. In this State, the SIC278 transponder will not respond to any commands.

Switching off the powering magnetic field or moving the SIC278 transponder out of the field that lets it enter the **"Power Off"** state.

3.1.6 Tag-Talk-First (TTF) State

When configured in **"TTF"** Mode, if the SIC278 transponder does not receive the **GET_UID xx** command within the mode switch window, the transponder will enter this state. Once entered this state, the SIC278 transponder continuously transmits data with configurable data coding, data rate, and data length, and any command from RWE will be discarded. The only way to get out of this state is to switch off the powering magnetic field or move the SIC278 transponder out of the field that lets it enter the **"Power Off"** state.

The SIC278 transponder configured in **"TTF"** mode can be switched temporarily into Reader-Talk-First (**"RTF"**) mode by transmitting a **GET_UID xx** command within a defined time frame after turning ON the powering field. The SIC278 transponder will quit the temporary **"RTF"** mode after turning OFF the powering field or moving out of the RWE antenna field.

4. Memory organization

The 32 x 44 blocks (1,408 bits) of a Read/Write EEPROM memory are organized for configuration and user data area as shown in Figure 4-1. The memory is defined by a block or by a page. A page consists of 4 blocks, while a block consists of 32 bits. The smallest unit of memory that can be read or written is 32 bits (1 block).

		31	0
PADR0	BADR 0	UID	
	BADR 1	Configuration	
	BADR 2	PWD_W	
	BADR 3	PWD_R	
PADR1	BADR 4	User Memory	
	BADR 5	User Memory	
PADR10	BADR 40	User Memory	
	BADR 41	C-tune Value	
	BADR 42	Traceability Data 0	
	BADR 43	Traceability Data 1	

Figure 4-1: SIC278 Memory Organization

4.1 Package and Dimension Unique Identifier (UID)

Referring to Figure 4-1, the 32 bits Unique Identifier (UID) is located at Block 0x00, Page 0. The UID is programmed during the manufacturing process. After programming, Block 0 will become read-only (RO).

Block Address	MSByte				LSByte			
	31	24	23	16	15	8	7	0
0x00	UID 3		UID 2		UID 1		UID 0	
	PID 1	PID 0						

Figure 4-2: Unique Identifier (UID)

4.1.1 Product Identifier (PID)

According to Figure 4-2, the Product Identifier (PID) in SIC278 IC is encoded in the UID-3 Byte of the Unique Identifier (UID). This function allows the user to distinguish different revisions of SIC278s.

4.2 SIC278 in Standard Mode

- Block 1 included four configuration Bytes (**CON 0**, **CON 1**, **CON 2**, and **CON 3**).
- Block 2-40 (0x02 – 0x28) can be utilized for storing user data.

Block Address	MSByte				LSByte			
	31	24	23	16	15	8	7	0
0x00	UID 3		UID 2		UID 1		UID 0	
0x01	CON 3		CON 2		CON 1		CON 0	
0x02	Data 3		Data 2		Data 1		Data 0	
...	
0x28	Data 3		Data 2		Data 1		Data 0	

Figure 4-3: Memory Map for SIC278 in Standard Mode

4.3 SIC278 in Password Mode

- Block 1 includes four configuration Bytes (**CON 0**, **CON 1**, **CON 2**, and **CON 3**).
- Block 2 is a 32-bit write-protection password (**PWD_W**).
- Block 3 is a 32-bit read-protection password. (**PWD_R**).
- Block 4 - 40 (0x04 – 0x28) can be utilized for storing user data.

Block Address	MSByte				LSByte			
	31	24	23	16	15	8	7	0
0x00	UID 3		UID 2		UID 1		UID 0	
0x01	CON 3		CON 2		CON 1		CON 0	
0x02	PWD_W3		PWD_W2		PWD_W1		PWD_W0	
0x03	PWD_R3		PWD_R2		PWD_R1		PWD_R0	
0x04	Data 3		Data 2		Data 1		Data 0	
...	
0x28	Data 3		Data 2		Data 1		Data 0	

Figure 4-4: Memory Map for SIC278 in Password Mode

5. SIC278 Configuration

5.1 Configuration block

The configuration block (block address 1) has 32 bits as shown in Figure 5-1.

CON3:	31	X	X	FSK	PWD_R	X	MBL(2)	X	24	X
CON2:	23	PWD_W	MC /DBP	DR(1)	DR(0)	MBL(1)	MBL(0)	LCK 1 (OTP)	16	LCK 2 - 3
CON1:	15	LCK 4 - 5	LCK 6 - 7	LCK 8 - 11	LCK 12 - 15	LCK 16 - 23	LCK 24 - 31	LCK 32 - 40	8	LCK 41 (CT)
COND:	7	X	X	X	X	X	X	X	0	X

Figure 5-1: Configuration block

Bit X is a don't care bit; it can be either '0' or '1'.

Bit FSK defines a Frequency-Shifted-Keying coding required by FDX-A Animal identification standard when sending data to the RWE. This coding bit will only affect when it is in the "TTF" state.

Bit MBLs define the number of blocks, which will be sent as a continuous loop while sending the data to the RWE. The bits setting will only affect when it is in the "TTF" state.

Table 5-1: SIC278 Max-Block

MBL(2)	MBL(1)	MBL(0)	Blocks, which is transmitted in TTF state
0	0	0	Disabled TTF Mode
0	0	1	Block 4 and 5
0	1	0	Block 4 to 7
0	1	1	Block 4 only
1	0	0	Disabled TTF Mode
1	0	1	Block 4 to 6
1	1	0	Block 4 to 9
1	1	1	Block 4 to 11

Bit (MC/DBP) describes the coding used when sending data to the RWE. This bit is valid when Bit FSK = 0. This bit will only affect when it is in the "TTF" state.

Table 5-2: SIC278 Coding Bit (MC/DBP)

MC/DBP	Coding In TTF State
0	Manchester
1	Differential Bi-phase

Bit PWD_W = '1', the SIC278 Transponder IC is set in Password Mode and can only be chosen with the **SELECT (UID)** command and a following secure Password Authorization sequence. If the Write Password Bit PWD_W = '0', the SIC278 Transponder IC is configured to Standard Mode and the corresponding UID.

Bit PWD_R (Read Password Bit) is only effective in Password Mode (PWD_W = '1'). With PWD_R = '1', the memory can only be read after the **SELECT (UID)** command and a successful following Password Authorization sequence.

Table 5-3: SIC278 Password Bit (PWD_W, PWD_R Bit)

PWD_W	PWD_R	Mode
0	0	No protection
0	1	No protection
1	0	Write-Protected Password Mode
1	1	Read/Write Protected Password Mode

DR (0) and **DR (1)** are for selecting the desirable data rate during sending the data to the RWE. These bit settings will only affect when it is in **"TTF"** State.

Table 5-4: SIC278 Data Rate Bits (DR(0) and DR(1))

DR(1)	DR(0)	Data Rate in TTF State
0	0	RF/32
0	1	RF/16
1	0	RF/64
1	1	RF/50

Bit **LCK 1** describes the write protection on the configuration block (block 1).

Table 5-5: SIC278 Lock Configuration

LCK 1	the write protection on the configuration block
0	Read/Write
1	CON 0 and CON 1 are OTP* CON 2 and CON 3 are Read Only

*OTP = One Time Programmable means data '0' can be programmed to data '1' but data '1' cannot be erased to data '0'.

Bit **LCK** describes the write protection on data blocks as follows.

Table 5-6: SIC278 Memory Lock Bits Description

SYMBOL	FUNCTION	ACCESS RIGHTS	COMMENT
LCK 2-3	Lock Block 2 and Block 3 (Lock PWD_W and PWD_R)	0 = Read / Write 1 = Read Only	OTP if LCK 1 = '1'
LCK 4-5	Lock Block 4 and Block 5		
LCK 6-7	Lock Block 6 and Block 7		
LCK 8-11	Lock Block 8 – Block 11		
LCK 12-15	Lock Block 12 – Block 15		
LCK 16-23	Lock Block 16 – Block 23		
LCK 24-31	Lock Block 24 – Block 31		
LCK 32-40	Lock Block 32 – Block 40		
LCK 41 (CT)	Lock Block 41 (Lock tuning capacitor value)		

Remarks:

- After the configuration page is set, the SIC278 Tag/transponder needs to be reset to make the changes effective. The reset can be achieved by turning RF power off for more than 90ms or sending a wrong command to the transponder, such as requesting UID (while the transponder is in selected state), sending a wrong CRC command, trying to write data in block 0 (UID), etc.
- To prevent password access, **LCK 1** and **LCK 2-3** must be set to '1'.

5.2 Factory Default Memory

Block Addr	0	31	0	31	0
Block Addr 0	UID		Factory running number		
Block Addr 1	Configuration		0xCA	48	00 00
Block Addr 2	User memory or PWD_W		0xAA	AA	AA AA
Block Addr 3	User memory or PWD_R		0x55	55	55 55
Block Addr 4	User memory		128-bit Animal ID (Dummy number)		
Block Addr 5	User memory				
Block Addr 6	User memory				
Block Addr 7	User memory				
Block Addr 8	User memory		0xAA	AA	AA AA
Block Addr 9	User memory		0x55	55	55 55
		⋮			⋮
Block Addr 40	User memory		0xAA	AA	AA AA
Block Addr 41	C tune value		CT = 0x10 (16d)		
Block Addr 42	Traceability data 0		Factory running number		
Block Addr 43	Traceability data 1		Factory running number		

Figure 5-2: Factory Default Memory

- Unique ID is a factory running number for anti-collision purposes. This data is reserved for read-only.
- Configuration block and data block 4 – 7 are factory set as dummy 128-bit animal ID for ISO11784/5 standard (FDX-B). Recommend user reprogram the 128-bit to the user's purpose number.
- Resonant capacitor calibration value (CT) in block 41 is set as 16 from 0 to 31 steps.
- The traceability data is the factory running number for manufacturer tracking purposes. This data is reserved for read-only.

6. Communication

6.1 Downlink Mode

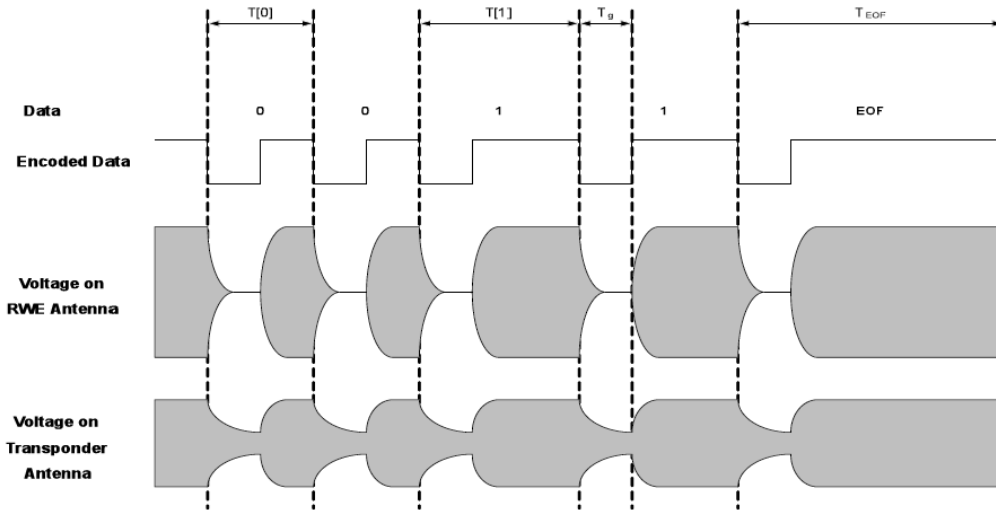

Figure 6-1: Data transmission from RWE to transponder

Data Information is transmitted to the SIC278 tag by using Amplitude Shift Keying (ASK) modulation with a modulation index of 100%. When the power field is turned off, the physical state is changed to a low field, otherwise, high field.

6.1.1 Coding

Binary Pulse Length Coding (BPLC) is used to encode the data stream. All coded data Bits and the End of Frame (EOF) condition start with a low length T_g . Then, the field is switched back ON again.

- '0' and '1' can be differentiated by the duration of $T[0]$ and $T[1]$.
- The end of the data transmission is identified by an end-of-frame (EOF) condition.

Table 6-1: Illustrates the data transmission from the RWE to SIC278 tag.

Symbol	Description	Duration
T_g	Gap Time	4...10 $T_0(1)$
$T_{[0]}$	Logic 0 Bit Length	14..22 $T_0(1)$
$T_{[1]}$	Logic 1 Bit Length	26..32 $T_0(1)$
T_{EOF}	Duration for end of frame condition	> 36 T_0

- These application-specific values must be within this frame. However, the values must be optimized for each application depending on the rise and down times of the RWE antenna voltage and the Tag Antenna Quality factor.
- T_0 = Carrier period time (1/125kHz = 8us nominal)
- The Average Bit rate from the RWE to the SIC278 tag can be calculated by the following formula; Bit Rate = $2/(T[0]+T[1]) = 5.2$ kBit/s
- The end of each data sequence from the RWE to the SIC278 tag must be an EOF condition.

6.2 Uplink Mode

For the data transmission from SIC278 Transponder to the RWE, the implemented method is called 'load modulation'.

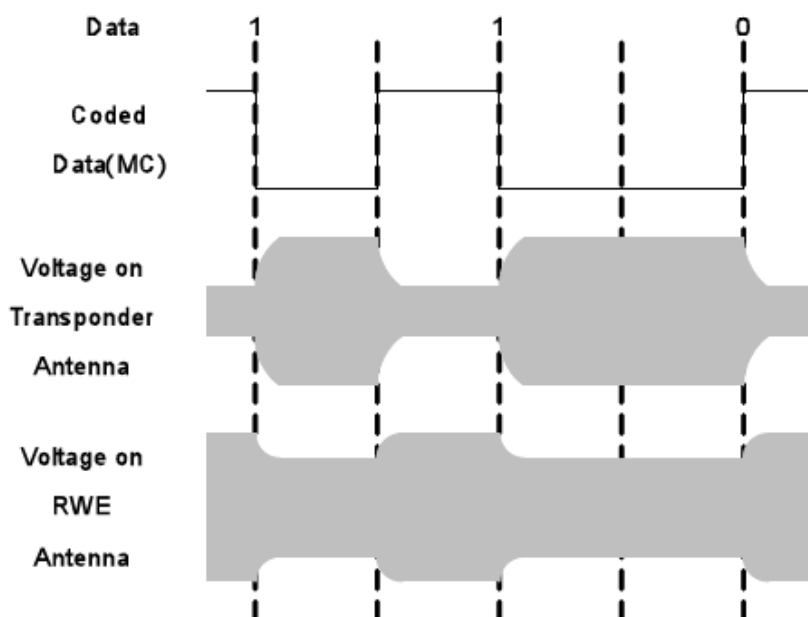

Figure 6-2: Example of Data Transmission for Uplink Mode (Tag to Reader)

With this 'load modulation' method, the SIC278 tag will continuously change the load depending on the magnetic field, theoretically by turning on/off a resistor according to the data to transmit. An alteration of the magnetic field is detected by the receiver of the RWE.

The modulation ratio of the RWE antenna voltage depends on the coupling factor of the RWE antenna configuration (which is related to the size of RWE Antenna, the size of antenna, and the distance between the tag and reader).

6.2.1 Coding Technique of SIC278 Transponder IC

There are three different coding techniques for different states and modes that SIC278 Transponder IC is using, as stated below.

- Anti-C: Anti-Collision Coding in *"INIT"* state
- Manchester: Manchester Coding in Selected and in *"TTF"* State
- Bi-Phase: Bi-phase Coding in *"TTF"* State

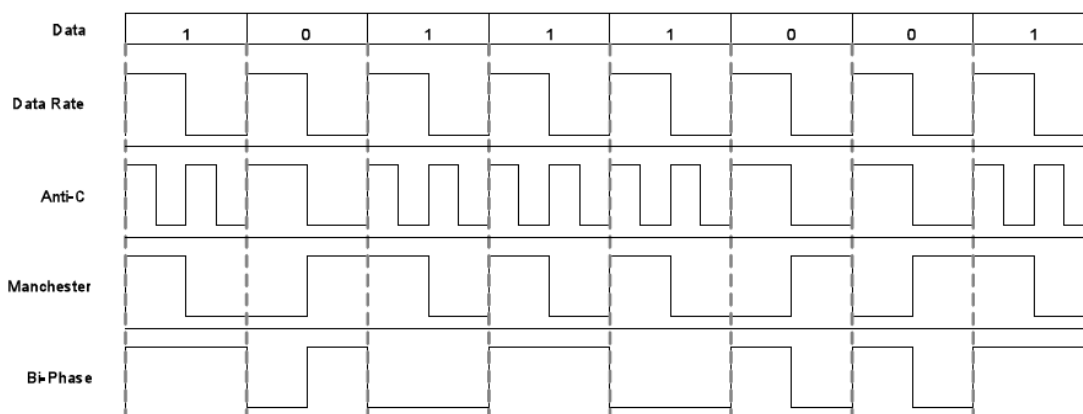

Figure 6-3: Coding Techniques of SIC278 Transponder

6.2.2 Data Rate

The data rate for SIC278 Transponder in RTF Mode depends on the corresponding **GET_UID xx** command. For **"TTF"** Mode, the data rate can be defined by a configuration setting.

Remark: $T_0 =$ Carrier period time ($1/125\text{kHz} = 8\mu\text{s}$ nominal)

Table 6-2: Data rate Mode Description

Mode	Coding	Bit Rate	Bit Length
SIC278 RTF Mode	Anti-C	2 kBit / s	$64 T_0$
		4 kBit / s	$32 T_0$
	Manchester	4 kBit / s	$32 T_0$
		8 kBit / s	$16 T_0$
SIC278 TTF Mode	Manchester	2 kBit / s	$64 T_0$
		4 kBit / s	$32 T_0$
		8 kBit / s	$16 T_0$
	Bi-phase	2 kBit / s	$64 T_0$
		4 kBit / s	$32 T_0$
		8 kBit / s	$16 T_0$
	FSK	2.5 kBit / s	$50 T_0$

6.3 Wait Timing (Idle time before next communication)

6.3.1 Read/Write Equipment waiting time before sending the first command

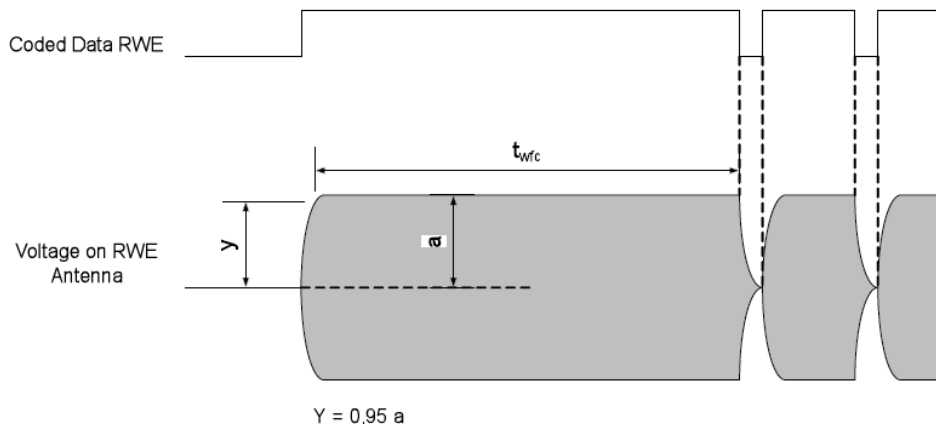

Figure 6-4: Read/Write Equipment Waiting Time before sending the first command

After switching ON the power field, the RWE must wait at least the minimum waiting time $t_{wfc} = 170T_0$ before transmitting the first command.

Table 6-3: t_{wfc} Waiting Time Range

	MIN	TYP	MAX	UNIT
t_{wfc}	170			T_0

6.3.2 Read/Write Equipment waiting time before sending a subsequent command

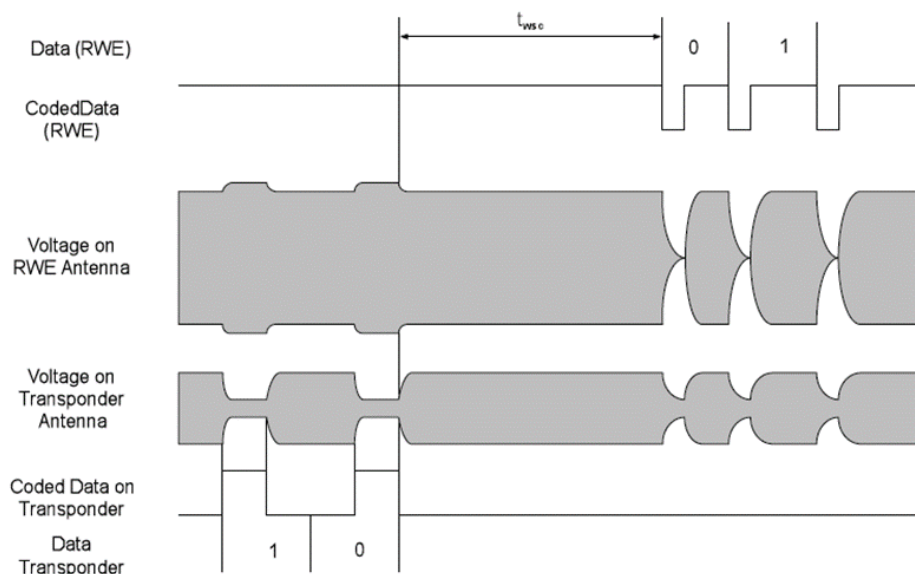

Figure 6-5: Read/Write Equipment Waiting Time before transmitting a subsequent command

When the RWE has received the response from the SIC278 Tag to a previous command, the RWE has to wait at least the minimum $t_{wsc} = 90T_0$ before transmitting a subsequent command or Write Data after Write Commands.

Table 6-4: t_{wsc} Waiting Time Range

	MIN	TYP	MAX	UNIT
t_{wsc}	90			T_0

6.3.3 Reset Time

The powering field has to be turned OFF at least $t_{reset} = 20ms$ to generate a reset state of the SIC278 transponder and to enter it into **"Power Off"** State.

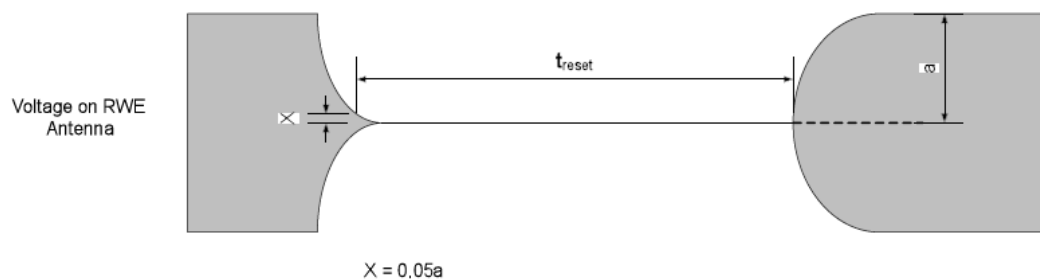

Table 6-5: t_{reset} Minimum time

	MIN	TYP	MAX	UNIT
t_{reset}	20	35	-	ms

6.3.4 SIC278 Waiting Time before transmitting a response after receiving an EOF

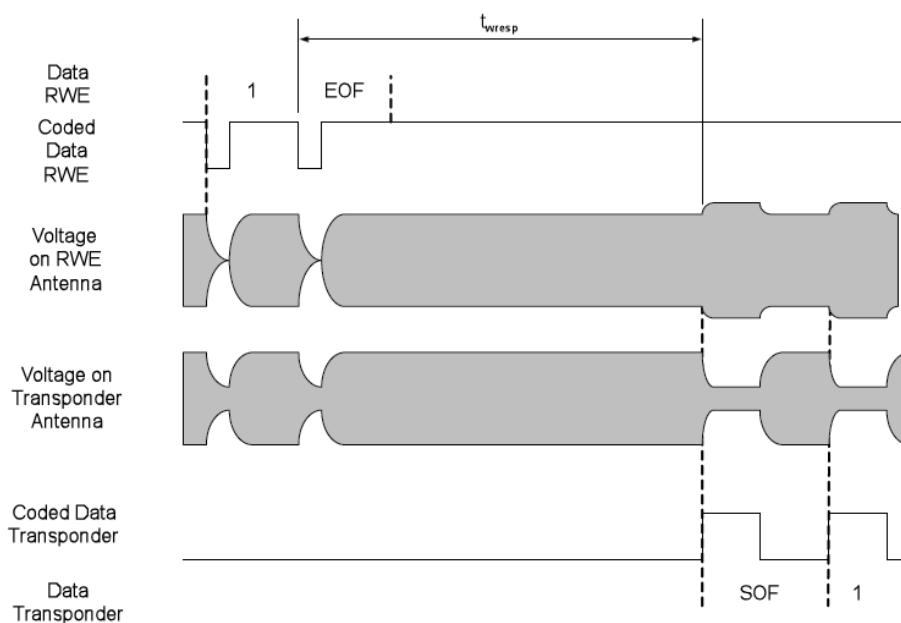

Figure 6-6: SIC278 Waiting Time before transmitting a response after receiving an EOF

When the SIC278 tag receives an End of Frame (EOF) condition from the RWE, the tag will wait t_{wresp} before transmitting data. The values given below are specific to transmission system parameters such as the coil's Quality factor, RWE antenna Quality factor.

(Note: * = Valid for coil quality factors $Q_{coil} < 30$)

Table 6-6: t_{wresp} Waiting Time Range

	MIN	TYP	MAX	UNIT
t_{wresp}^*	204	208	212	T_0

6.3.5 SIC278 Transponder Programming Time

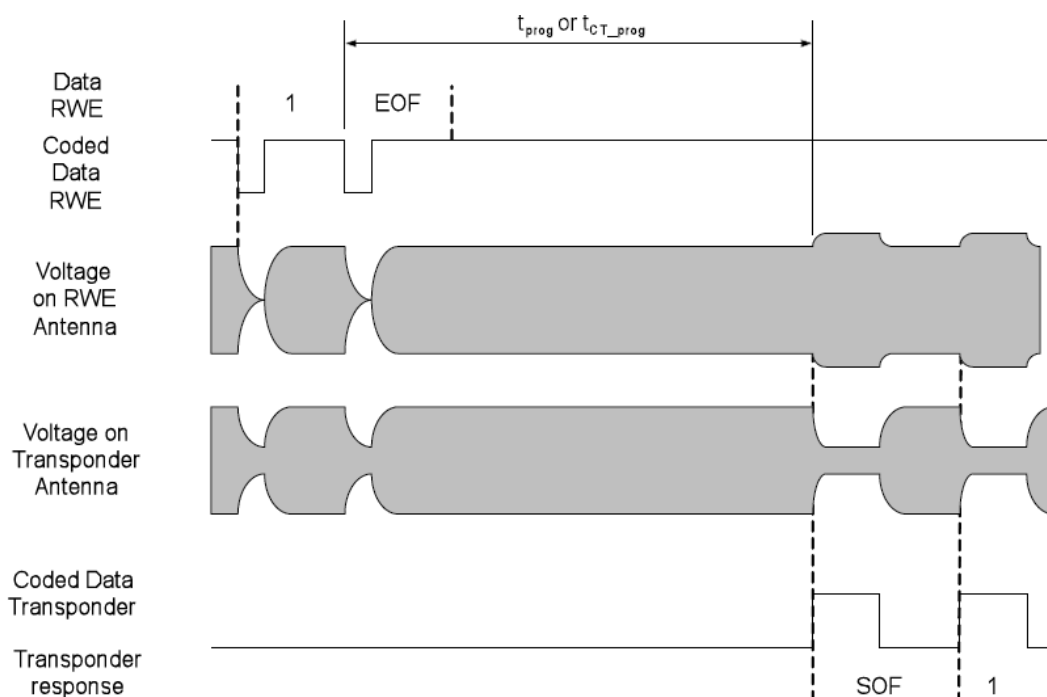

Figure 6-7: SIC278 Transponder Programming Time

When the SIC278 receives the EOF of the Write Data from the RWE, the transponder will wait t_{prog} before transmitting the SOF and acknowledging back to RWE to confirm the correct programming.

Table 6-7: t_{prog} or t_{CT_prog} Waiting Time Range

	MIN	TYP	MAX	UNIT
t_{prog}	716	721	726	T_0
t_{CT_prog}	4470	4480	4490	T_0

6.3.6 SIC278 Waiting Time before transmitting data in TTF Mode

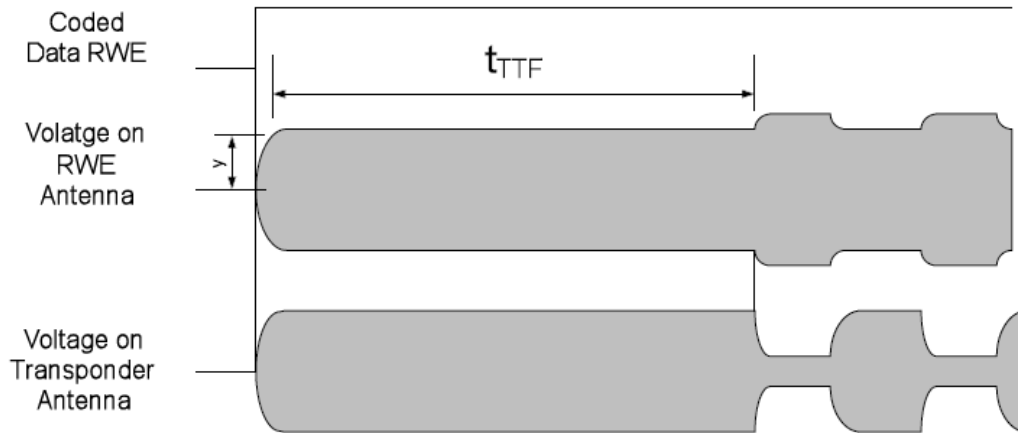

Figure 6-8: SIC278 Waiting Time before transmitting data in TTF Mode

After switching ON the powering field, the SIC278 transponder will wait t_{TTF} before transmitting data if it is configured in "TTF" Mode.

Table 6-8: t_{TTF} Waiting Time Range

	MIN	TYP	MAX	UNIT
t_{TTF}	570	597	625	T_0

6.3.7 SIC278 Transponder Mode Switching Time

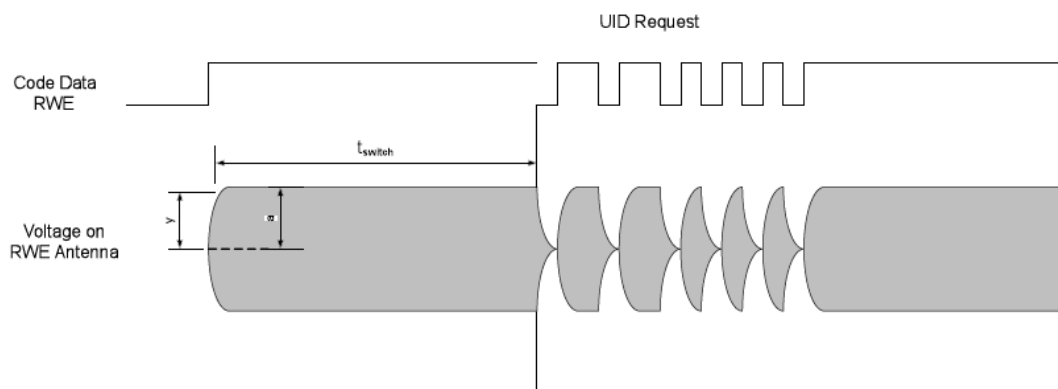

Figure 6-9: SIC278 Transponder Mode Switching Time

With a **GET_UID xx** command starting with the first bit after t_{switch} , a SIC278 transponder, which is configured in TTF Mode, can be switched into RTF Mode. The RWE has to wait at least the minimum time $t_{switch} = 220 T_0$ and shall not wait longer than the maximum time $t_{switch} = 520 T_0$. The SIC278 transponder shall respond to this command with UID and change into "INIT" State.

Table 6-9: t_{switch} Waiting Time Range

	MIN	TYP	MAX	UNIT
t_{switch}	220	350	520	T_0

7. Commands

7.1 GET_UID xx

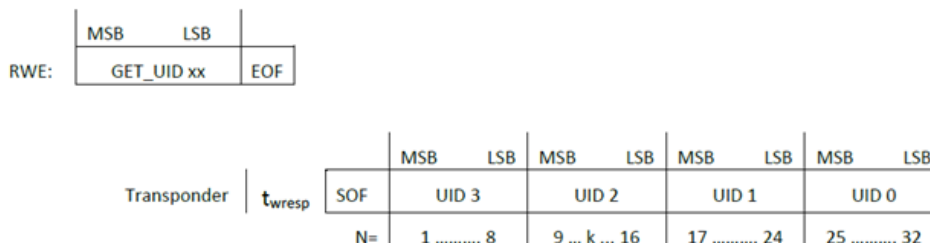

Figure 7-1: GET_UID Bit Stream

Remark:

- N.... PHYSICAL Bit position during air transmission. N = 25 is the bit with the highest valence, 231.
- K.... Any collision position (See command 'Anti-C SEQUENCE').

After the RWE sends this command, all SIC278 transponders located in the field of the RWE antenna will respond with a SOF pattern followed by the corresponding 32-bit UID. The complete response of the SIC278 transponder is sent in Anti-C Coding.

Table 7-1: Coding

	MSB	LSB	Response Protocol Mode
GET_UID Std	0	0 1 1 0	Standard
GET_UID Adv	1	1 0 0 y	Advanced
GET_UID FAdv	1	1 0 1 0	Fast Advanced

Note: y ...can be '0' or '1'

The Response Protocol Mode identified by the corresponding **GET_UID xx** command determines the coding, data rate, and the SOF pattern of the SIC278 transponder response.

Table 7-2: GET_UID Response Protocol Mode Description

Response Protocol Mode	SOF	CODING	DATA RATE
Standard	'1'	Anti-C	2 kBit/s
Advanced	'111'	Anti-C	2 kBit/s
Fast Advanced	'111'	Anti-C	4 kBit/s

- The SIC278 transponder in Ready State changes into **"INIT"** State after it receives a correct **GET_UID xx** command.
- The SIC278 transponder, being ready in **"INIT"** state, will remain in **"INIT"** State after receiving a further correct **GET_UID xx** command.
- The latest **GET_UID xx** command always defines the Response Protocol Mode for the following commands.

7.2 Anti-C SEQUENCE

If there is more than one SIC278 transponder in the field of the antenna, a specially designed RWE will detect the first collision at the Bit position $N = k$ of the UID response. As a result, the RWE shall then start an Anti-Collision sequence (**Anti-C SEQUENCE**).

This command consists of a 5-bit number (K4 to K0) defining the physical Bit position k where the collision occurred, followed by $(k-1)$ Bits of the detected UID and a Bit (one or zero) at the collision position. An 8-bit CRC of this sequence is also sent to the SIC278 transponders.

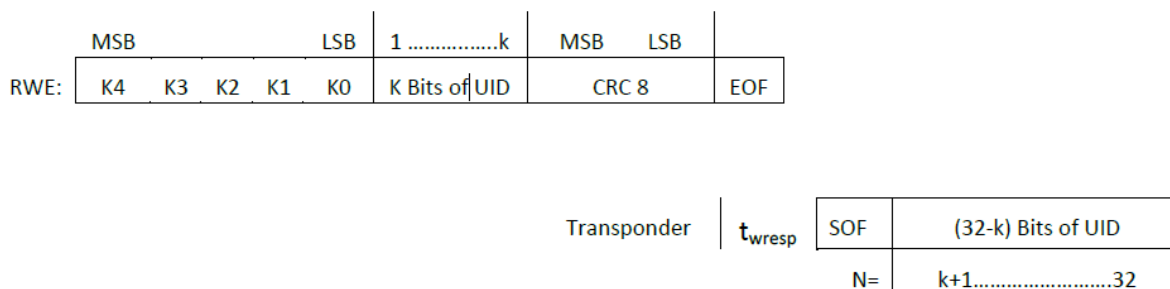

Figure 7-2: Anti-C SEQUENCE

After sending this command, all SIC278 transponders that first k Bits of their own UID match with the k received UID Bits shall respond with the SOF and the rest of their own UID.

In case a collision occurs again, the cited cycle has to be replaced until one valid UID of the transponders in the field is discovered. The complete response of the SIC278 transponder is sent Anti-C Coding.

Table 7-3: Anti-C SEQUENCE Response Protocol Mode Description

Response Protocol Mode	SOF	CODING	DATA RATE
Standard	'1'	Anti-C	2 kBit/s
Advanced	'111'	Anti-C	2 kBit/s
Fast Advanced	'111'	Anti-C	4 kBit/s

During the **Anti-C SEQUENCE** commands, the SIC278 transponder stays in the **"INIT"** state. Even those SIC278 transponders where the k received Bits of the UID do not match remain in **"INIT"** state.

7.3 WRITE CT

The **WRITE CT** or write tuning capacitor command is used for automatic transponder tuning in the manufacturing process. SIC278 transponder has 32 steps (5 bits) of internal tuning capacitor, each step has 0.7pF. Write block/page command in the selected state cannot write data in the block address 41. The only **WRITE CT** command can write data into the 41st block address while it is in the **"INIT"** state.

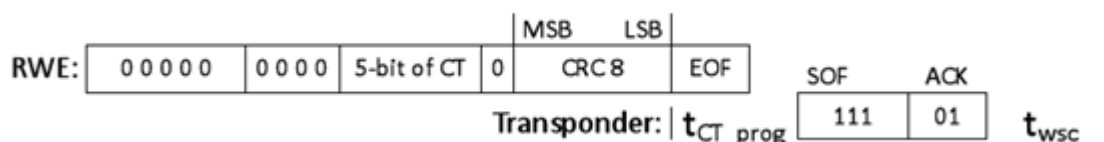

Figure 7-3: WRITE CT

Please note that transponder response data is Anti-C Coding.

7.4 READ CT

The **READ CT** or read tuning capacitor command is used for automatic transponder tuning in the manufacturing process. The 5-bit tuning capacitors are bits 9th to 13th of data in block address 41. The 13th bit is the MSB with the largest tuning capacitance. With this command, a SIC278 transponder must be in the **"INIT"** State.



Figure 7-4: READ CT

Please note that transponder response data is Anti-C Coding.

7.5 SELECT (UID)

The **SELECT (UID)** command consists of 5 Zero-Bits followed by the defined 32-bit UID and an 8-bit Cyclic Redundancy Check (CRC). The chosen SIC278 transponder then responds with a start of the frame pattern (SOF), followed by the content of the Configuration Block, and depending on the Response Protocol Mode, with an 8-bit CRC.

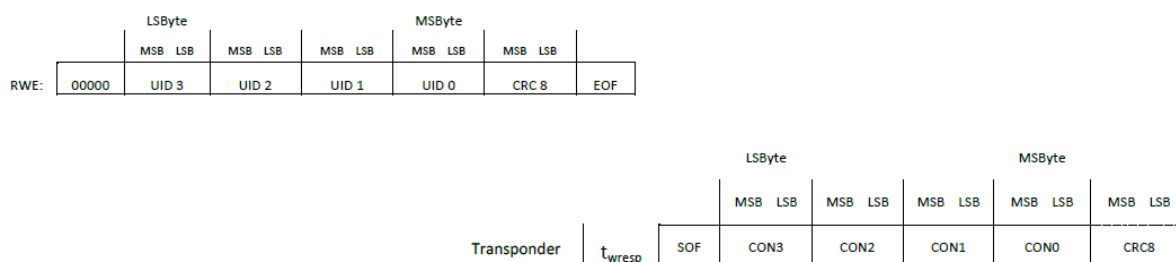

Figure 7-5: SELECT (UID)

The complete response of SIC278 transponder is sent in Manchester Coding.

The SIC278 transponder will change into Selected State after receiving a correct **SELECT (UID)** command.

Table 7-4: SELECT (UID) Response Protocol Mode Description

Response Protocol Mode	SOF	CRC8	CODING	DATA RATE
Standard	'1'	No	Manchester	4 kBit/s
Advanced	'111111'	Yes	Manchester	4 kBit/s
Fast Advanced	'111111'	Yes	Manchester	8 kBit/s

7.7 SELECT_SILENT (UID)

With this command, a SIC278 transponder in **"INIT"** State can be directly put the tag into the **"SILENT"** Mode.

Please note that SOF pattern and the acknowledge (ACK) pattern are sent in Manchester Coding.

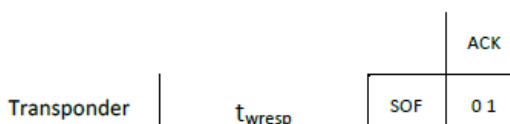
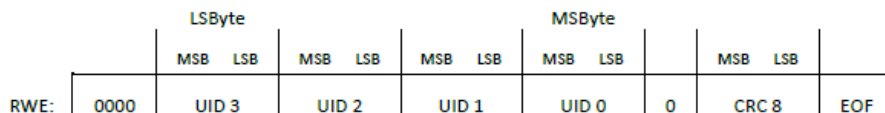

Figure 7-7: SELECT_SILENT (UID)

Once the tag is entered into **"SILENT"** State, SIC278 transponder can only be enabled by turning off the powering magnetic field for at least a time, t_{reset} , or the SIC278 transponder shall be removed from the antenna field (**"Power OFF"** State).

Table 7-6: SELECT_SILENT (UID) Response Protocol Mode Description

Response Protocol Mode	SOF	CODING	DATA RATE
Standard	'1'	Manchester	4 kBit/s
Advanced	'111111'	Manchester	4 kBit/s
Fast Advanced	'111111'	Manchester	8 kBit/s

7.8 READ BLOCK

After SIC278 transponder was chosen by the consequent **SELECT (UID)** command (or **SELECT (UID)** and **UNLOCK PASSWORD** for Password Mode), a read process of the stored data on the EEPROM can be performed.

After sending the **READ BLOCK** command, 8-bit Block Address (BADR) and 8-bit CRC8, the SIC278 transponder will respond with the SOF and 32 bits of data of the corresponding Block.



Figure 7-8: READ BLOCK

Please note that the highest Block Address (BADR) is 0x3F. As a result, the two highest Bits must be '0'.

7.9 READ PAGE

After sending the **READ PAGE** command, the 8-bit Block Address (BADR) within a Page and the 8-bit CRC (CRC8), the SIC278 transponder shall respond with the SOF and 128 Bits of data beginning with the address block (BADR) within the Page to the last Block of the corresponding Page.

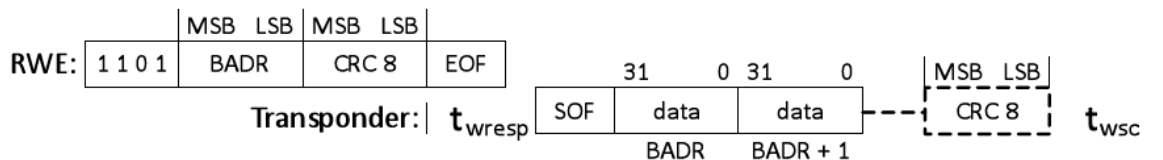

Figure 7-9: READ PAGE

Please note that the highest Block Address (BADR) is 0x3F. As a result, the two highest Bits must be '0'.

Table 7-7: READ BLOCK and READ PAGE Response Protocol Mode Description

Response Protocol Mode	SOF	CRC8	CODING	DATA RATE
Standard	'1'	No	Manchester	4 kBit/s
Advanced	'111111'	Yes	Manchester	4 kBit/s
Fast Advanced	'111111'	Yes	Manchester	8 kBit/s

7.10 WRITE BLOCK

After SIC278 transponder was chosen by the consequent **SELECT (UID)** command (or **SELECT (UID)** and **UNLOCK PASSWORD** for Password Mode), the write process of the data onto the SIC278 memory can be continued. Please note that MSByte is always sent first. For instance, the byte CON3 shall be sent first in order to change the configuration page.

After sending the **WRITE BLOCK** command, the 8-bit Block Address (BADR), and the 8-bit CRC (CRC8), the SIC278 transponder shall respond with the SOF and an Acknowledge (ACK) to confirm the reception of a correct **WRITE BLOCK** command. After it waits for the waiting time (t_{wsc}), the RWE shall send the write data with CRC8. After the programming time (t_{prog}), the SIC278 transponder shall respond with a SOF and an Acknowledge (ACK) to confirm the correct programming.

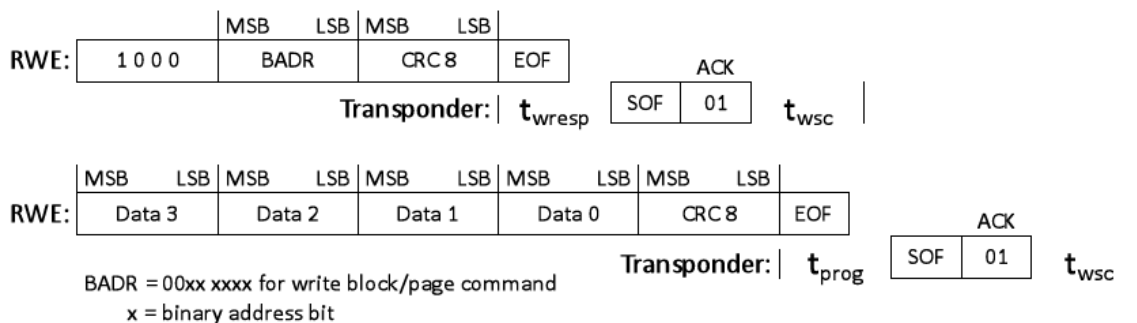

Figure 7-10: WRITE BLOCK

Table 7-8: WRITE BLOCK Response Protocol Mode Description

Response Protocol Mode	SOF	CODING	DATA RATE
Standard	'1'	Manchester	4 kBit/s
Advanced	'111111'	Manchester	4 kBit/s
Fast Advanced	'111111'	Manchester	8 kBit/s

7.11 WRITE PAGE

After sending the **WRITE PAGE** command, the 8-bit Block Address (BADR) within a page and the 8-bit CRC (CRC8), the SIC278 transponder shall respond with the SOF and an Acknowledge (ACK) to confirm the reception of a correct **WRITE PAGE** command. After it waits for the waiting time (t_{wsc}), the RWE shall send the write data with CRC8 block by block (1 to 4 blocks will be depending on the Block Address (BADR) within the corresponding page). After the programming time (t_{prog}), the SIC278 transponder shall respond with a SOF and an Acknowledge (ACK) to confirm the correct programming of each Page.

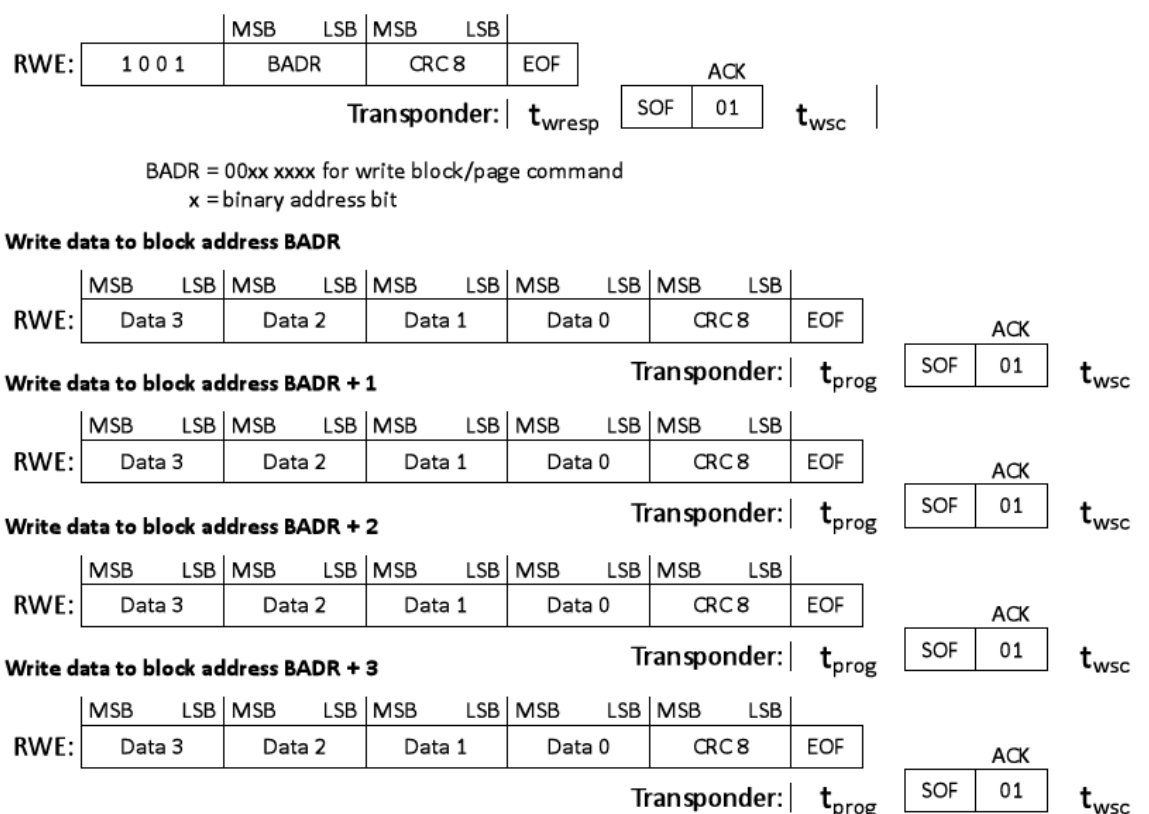

Figure 7-11: WRITE PAGE

Table 7-9: WRITE PAGE Response Protocol Mode Description

Response Protocol Mode	SOF	CODING	DATA RATE
Standard	'1'	Manchester	4 kBit/s
Advanced	'111111'	Manchester	4 kBit/s
Fast Advanced	'111111'	Manchester	8 kBit/s

7.12 SILENT

With the **SILENT** command, the selected SIC278 transponder can be put into the **"SILENT"** state. A valid 8-bit Block Address (BADR) and CRC 8 shall be transmitted for command structure reasons only.

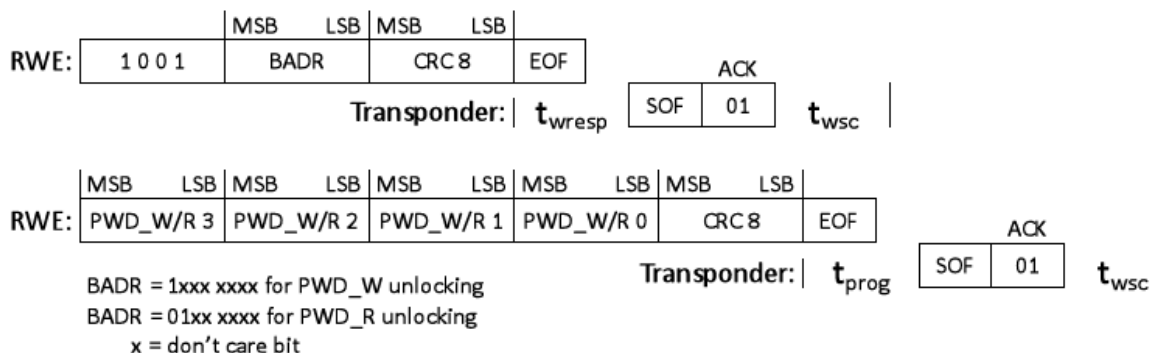

Figure 7-12: SILENT

After the response wait time (t_{wresp}), the SIC278 transponder shall respond with a SOF and an Acknowledge to confirm entering the **"SILENT"** State. Once a SIC278 transponder enters the **"SILENT"** State, it can only be reactivated after turning OFF the powering magnetic field for at least a time (t_{reset}) or the SIC278 transponder must be relocated out of the antenna field (called **"Power OFF"** State).

Table 7-10: SILENT Response Protocol Mode Description

Response Protocol Mode	SOF	CODING	DATA RATE
Standard	'1'	Manchester	4 kBit/s
Advanced	'111111'	Manchester	4 kBit/s
Fast Advanced	'111111'	Manchester	8 kBit/s

8. Public Mode

When configured in “TTF” Mode, if the SIC278 transponder does not receive the **GET_UID xx** command within the Mode switch window, the transponder will enter this State. Once entered this State, the SIC278 transponder continuously transmits data with configurable data coding, data rate, and data length.

This “TTF” Mode of SIC278 transponder allows data transmission to an RWE without sending any command to trigger the tag. The “TTF” Mode can be enabled/disabled and set by setting the corresponding Bits of the Configuration byte CON1 (Please refer to Section 5, Configuration).

The SIC278 transponder configured in “TTF” Mode can be switched temporarily into Reader-Talk-First (RTF) Mode by transmitting a **GET_UID xx** command within a defined time frame after turning ON the powering field.

The SIC278 transponder will quit the temporary “RTF” Mode after turning OFF the powering field or moving out of the RWE antenna field.

If the SIC278 transponder is set in “TTF” Mode and no Mode switch command is sent by the RWE within the defined time frame, it shall enter the “TTF” State. The SIC278 transponder shall transmit the data with different coding, data rate, and data length depending on the configuration. It is suggested to use some of the data bits as well as a defined start sequence.

8.1 ISO11784/85 Animal ID Using 128 Bit TTF Mode (FDX-B)

CON3:	31	X	X	FSK	PWD_R	X	MBL(2)	X	X	24
CON2:	23	X	X	0	Y	X	0	X	X	16
CON1:	15	Y	1	0	0	1	0	Y	Y	8
CON0:	7	X	X	X	X	X	X	X	X	0
		X	X	X	X	X	X	X	X	

X = don't care bit Y = upon user define

Figure 8-1: Configuration for 128-bit TTF with differential bi-phase coding

With this setting, the SIC278 transponder continuously transmits the data content of Page 4 to Page 7 with differential bi-phase coding and RF/32 data rate.

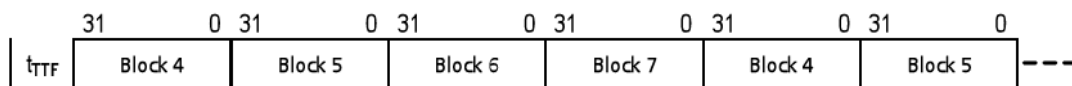

Figure 8-2: Transponder Data Transmission – 128 bits TTF Mode

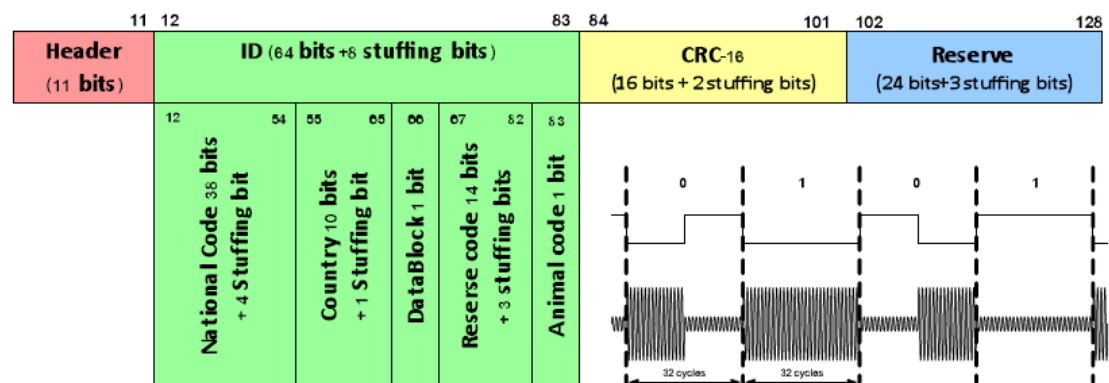

Figure 8-3: 128-bit FDX-B data format and RF signal structure of differential bi-phase coding, RF/32 data rate

8.2 FECAVA Animal ID

CON3:	X	X	FSK	PWD_R	X	MBL(2)	X	X
CON2:	PWD_W	MC / DBP	DR(1)	DR(0)	MBL(1)	MBL(0)	LCK 1 (OTP)	LCK 2-3
CON1:	LCK 4-5	LCK 6-7	LCK 8-11	LCK 12-15	LCK 16-23	LCK 24-31	LCK 32-40	LCK 41 (CT)
COND:	X	X	X	X	X	X	X	X

Figure 8-4: Configuration for 96-bit TTF with FSK coding

With this setting, the SIC278 transponder continuously transmits the data content of Page 4 to Page 6 with FSK coding and RF/50 data rate.



Figure 8-5: Transponder Data Transmission – 96 bits TTF Mode

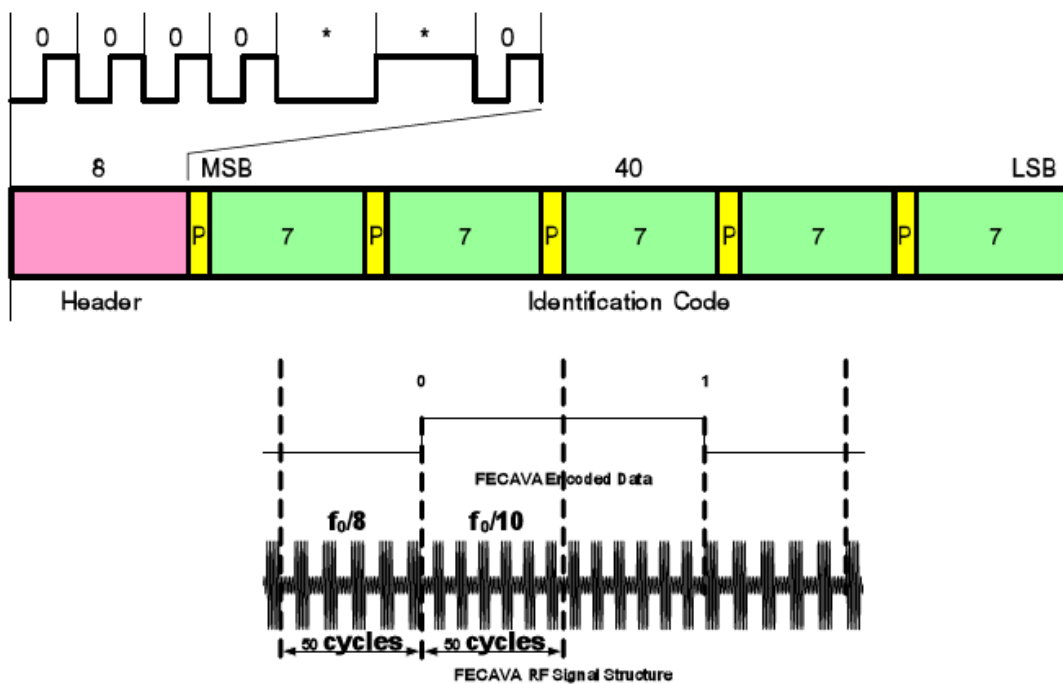

Figure 8-6: 48-bit FDX-A data format and RF signal structure of FSK coding, RF/100 data rate

8.3 64-bit ID Format

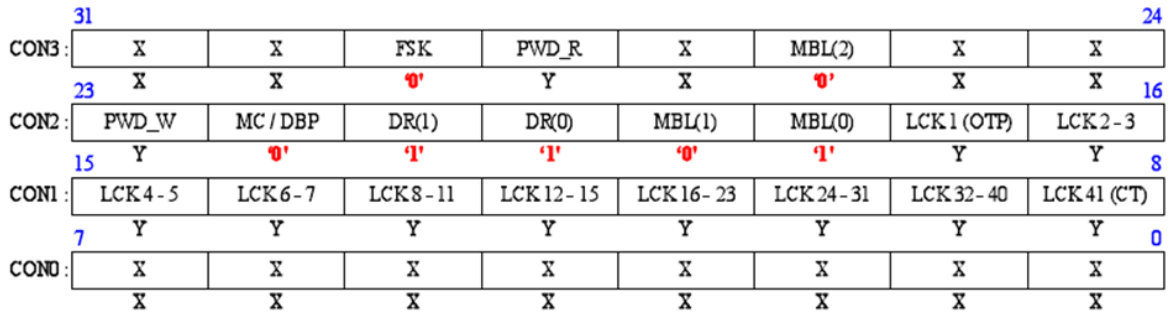

Figure 8-7: Configuration for 64-bit ID TTF with Manchester coding

With this setting, the SIC278 transponder continuously transmits the data content of Page 4 to Page 5 with Manchester coding and RF/64 data rate.

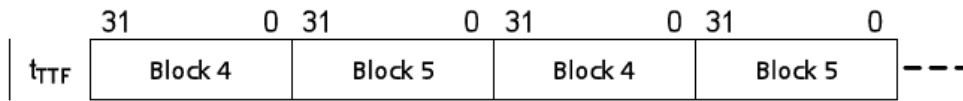

Figure 8-8: Transponder Data Transmission – 64 bits TTF Mode

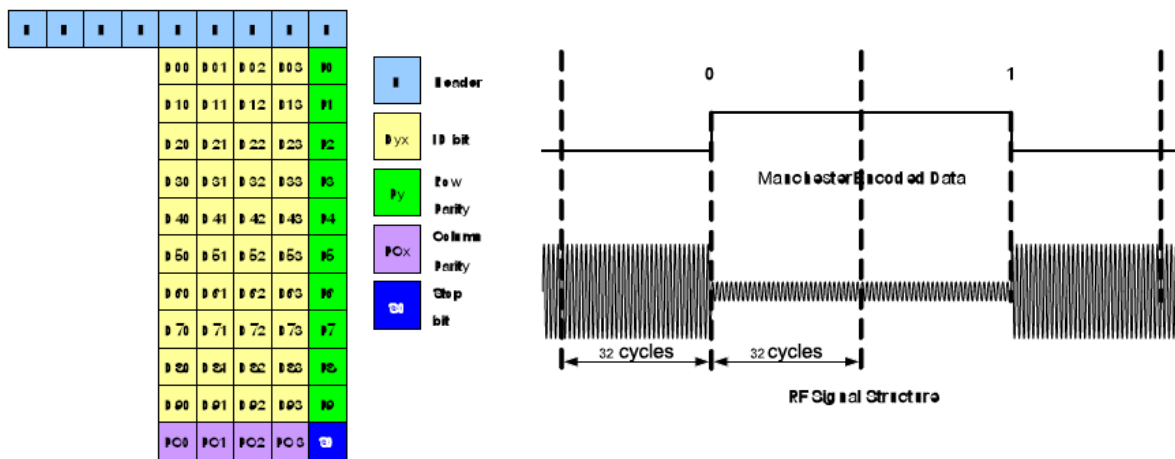

Figure 8-9: 64-bit ID format and RF signal structure of Manchester coding, RF/64 data rate

9. CRC Calculation / Integrity Check

This section describes the features of SIC278 protocol to protect read and write access to SIC278 transponders from undetected errors.

9.1 Data Transmission: RWE to SIC278 transponder

Every data stream sent by the RWE to the SIC278 transponder included an 8-bit CRC.

In the first state, the data stream is checked for data errors by the SIC278 transponder and executed.

The generator polynomial for the CRC-8 is;

$$U^8 + U^4 + U^3 + U^2 + 1 = 0x1D$$

The CRC preset value is 0xFF

9.2 Data Transmission: SIC278 transponder to RWE

9.2.1 Standard Response Protocol Mode

In this mode, the SIC278 transponder response does not include any checksum. Since checksum data integrity has to be calculated by the user software and stored altogether with the information in the transponder.

9.2.2 Advanced/ Fast Advanced Response Protocol Mode

In this Advanced Mode, the response on a **SELECT (UID)**, **READ PAGE**, **READ BLOCK** command shall include a CRC8 checksum.

The generator polynomial for the CRC-8 is

$$U^8 + U^4 + U^3 + U^2 + 1 = 0x1D$$

The CRC preset value is 0xFF

9.3 CRC Checksum Source Code

In case the user wants to modify the user's firmware on the microcontroller, the following C programming code for CRC calculation is shown, for example, as follows.

```
void CRC_SIC7888(void)
{
    unsigned char i, j, k, crc;
    unsigned char data_len; // number of data bit
    unsigned char data[5]; // array of data

    // if we want to generate crc of 10-bit data such as 00101 11001.
    data_len = 10;
    data[0] = 0b00101110;
    data[1] = 0b01000000;
    crc = 0xFF; // CRC preset value
    i = 8; j = 0;
    while(data_len > 0)
    {
        if(i >= 8)
        {
            i = 0;
            crc ^= data[j];
            j++;
        }
        if ((crc & 0x80) == 0x00)
        {
            crc <<= 1;
        }
        else
        {
            crc <<= 1;
            crc ^= 0x1D;
        }
        i++;
        data_len--;
    }
    // and after calculation, crc = 0b10101110
}
```

10. Package Information

10.1 WDFN 1.5x1.8 mm

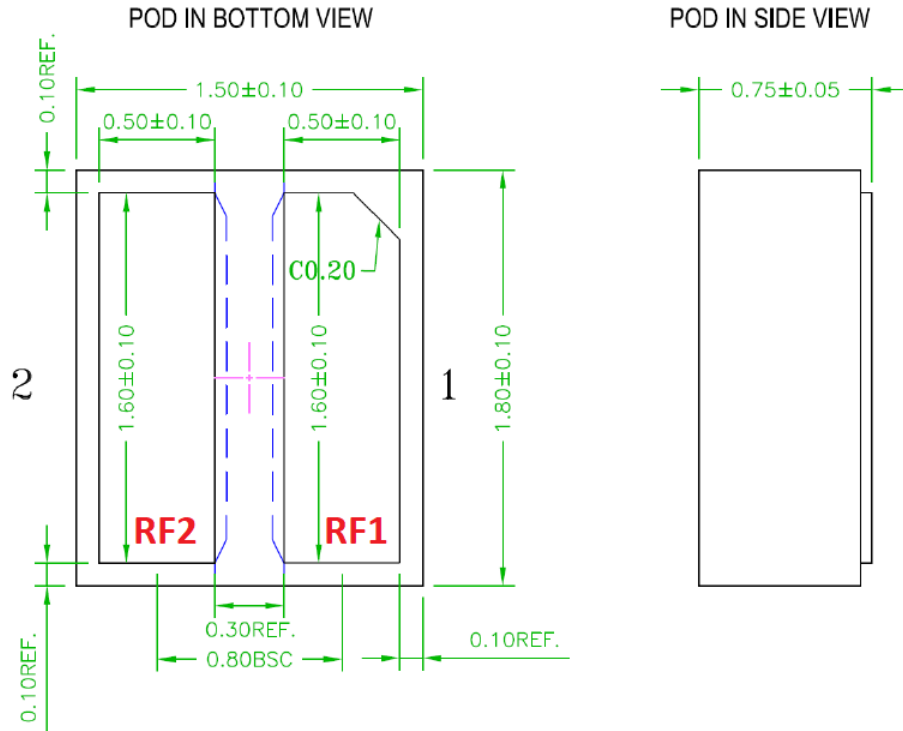

Figure 10-1: WDFN 1.5x1.8 mm Package Drawing

11. Disclaimer

- The information described herein is subject to change without notice.
- Although the IC contains a static electricity protection circuit, static electricity or voltage that exceeds the limit of the protection circuit should not be applied.
- Silicon Craft Technology assumes no responsibility for the way in which this IC is used in products created using this IC or for the specifications of that product, nor does Silicon Craft Tech. Assume any responsibility for any infringement of patents or copyrights by products that include this IC either in Thailand or in other countries.
- Silicon Craft Technology is not responsible for any problems caused by circuits or diagrams described herein whose related industrial properties, patents, or other rights belong to third parties. The application circuit examples explain typical applications of the products, and do not guarantee the success of any specific mass-production design.
- Use of the information described herein for other purposes and/or reproduction or copying without the express permission of Silicon Craft Technology is strictly prohibited.
- The products described herein cannot be used as part of any device or equipment affecting the human body, such as exercise equipment, medical equipment, security systems, gas equipment, or any apparatus installed in airplanes and other vehicles, without prior written permission of Silicon Craft Technology.
- Although Silicon Craft Technology exerts the greatest possible effort to ensure high quality and reliability, the failure or malfunction of semiconductor products may occur. The user of these products should therefore give thorough consideration to safety design, including redundancy, fire-prevention measures, and malfunction prevention, to prevent any accidents, fires, or community damage that may ensue.